

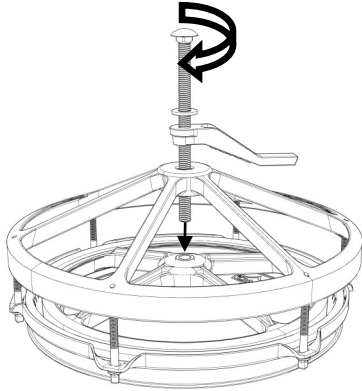

ROTOTOM ASSEMBLY INSTRUCTIONS

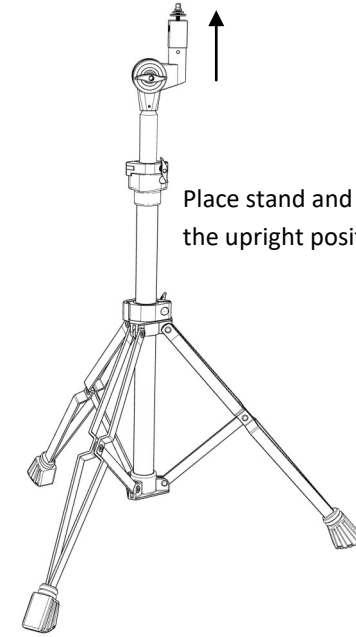

Turn the long carriage bolt clockwise until it makes contact with the bottom insert.

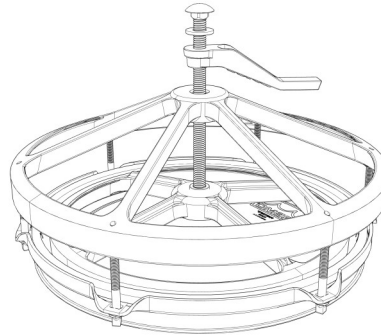

Place stand and tilter in the upright position.

Slide the short carriage bolt into the Rototracer approximately to the midway point. Tighten the AD10 adaptor plate to the Rototracer using the washer, nut, and included wrench. Place Rototracer assembly on top of the Ratchet Block Tilter.

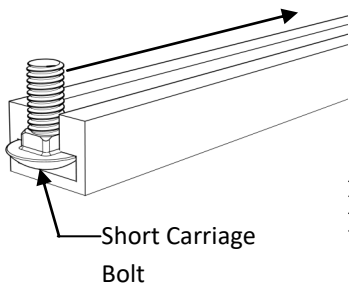

Short Carriage Bolt

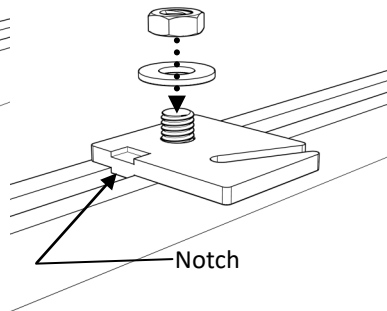

Notch

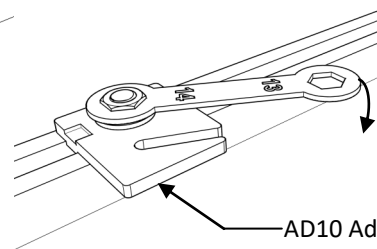

AD10 Adaptor Plate

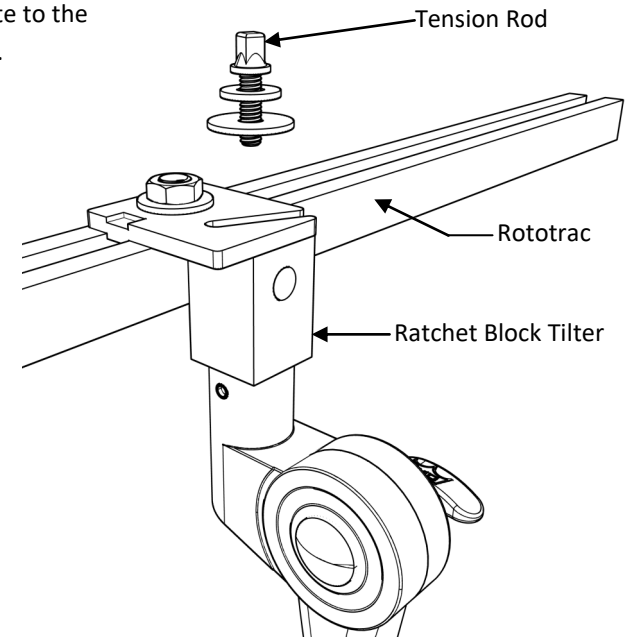

Tension Rod

Rototracer

Ratchet Block Tilter

Tighten AD10 & Rototrac to the Ratchet Block with the included Dum Key.

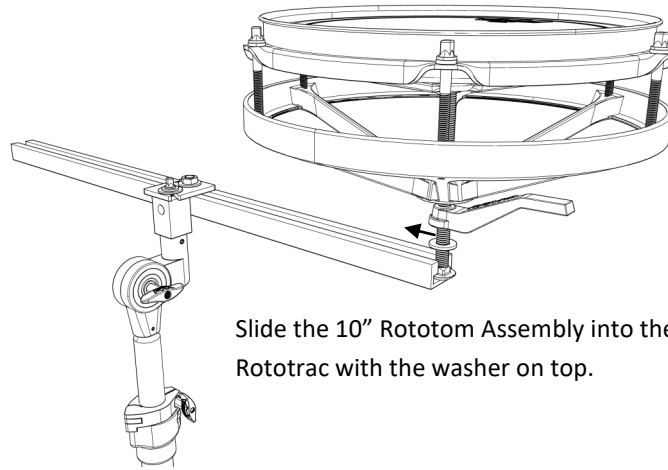
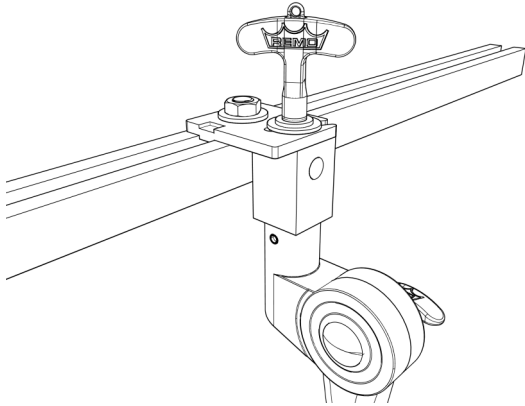

Slide the 10" Rototom Assembly into the Rototrac with the washer on top.

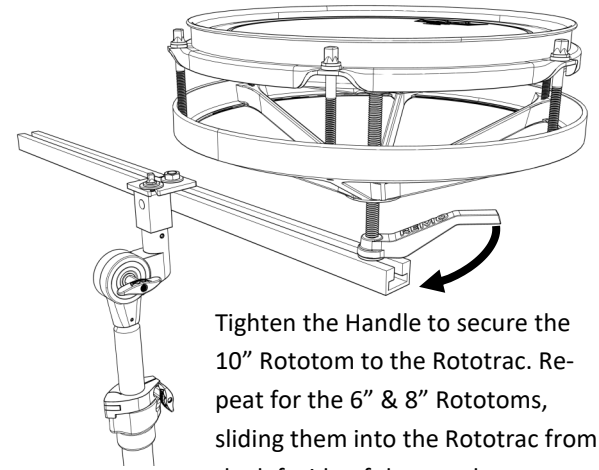

Tighten the Handle to secure the 10" Rototom to the Rototrac. Repeat for the 6" & 8" Rototoms, sliding them into the Rototrac from the left side of the stand.

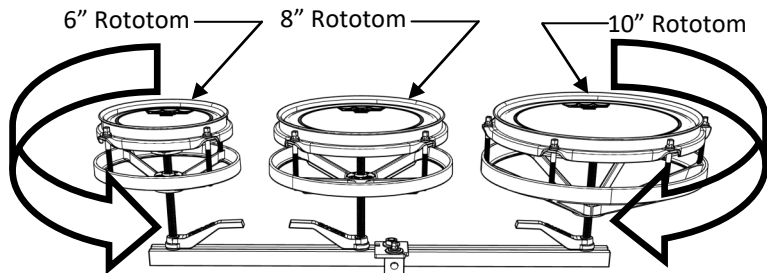

Rotate the entire Rototom assembly Counter Clockwise to decrease the pitch.

Rotate the entire Rototom assembly Clockwise to increase the pitch.

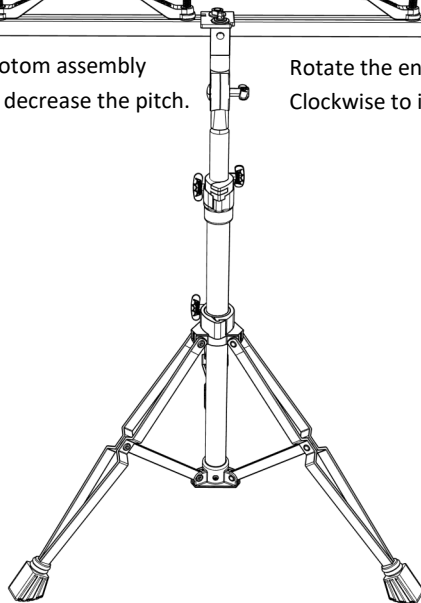

Tension Rods should be threaded all the way through and even on the bottom casting

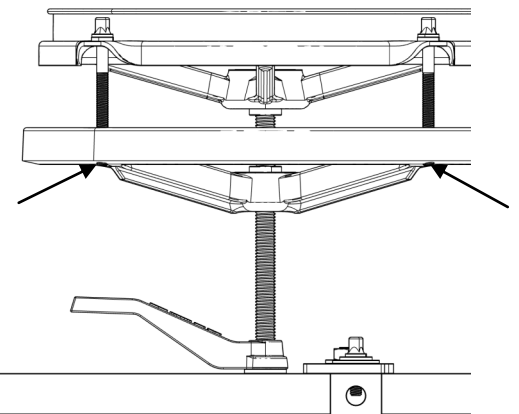
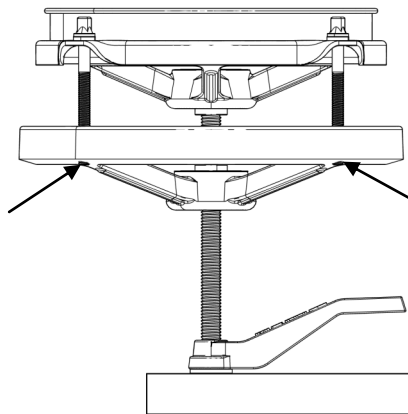

For more information visit: remo.com